



Aritco 9000 Platform Lift



Aritco 9000 **- our platform lift with cabin and automatic run**

Aritco 9000 is our cabin lift for the accessibility market. The lift is designed to meet all requirements for quality, safety and service. It is a perfect fit for tough and demanding environments such as schools, shops and residential buildings.

Several advantages offered by Aritco 9000:

- Design, sizes and options tailored to public environments
- 95% recyclable materials
- 'A' rated energy consumption according to VDI4707
- Patented screw/nut technology (no oil that can leak)
- The lowest maintenance and operating costs on the market
- Cabin control: Automatic "one-touch"



Aritco 9000

Platform Lift



Width

Length

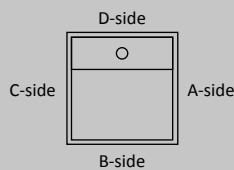

1000 x 1400

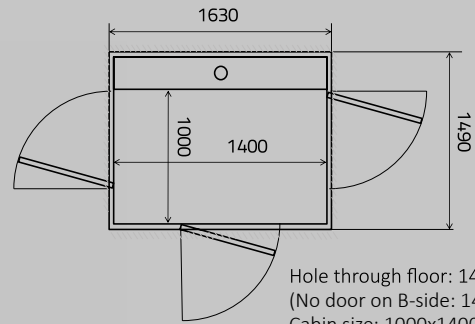

Hole through floor: 1490x1630 mm
(No door on B-side: 1465x1630 mm)
Cabin size: 1000x1400 mm
Load: 400 kg
Wheelchair: A or B with attendant*

1100 x 1400

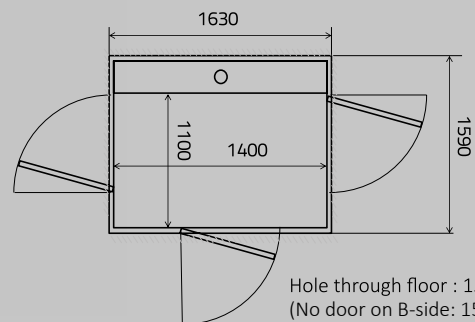

Hole through floor : 1590x1630 mm
(No door on B-side: 1565x1630 mm)
Cabin size: 1100x1400 mm
Load: 400 kg
Wheelchair: A or B with attendant,
adjacent entry*

Wheelchair Type A and B according to EN 12183/EN 12184.
* National guidelines may apply.

Dimensions

Cabin width..... 1000-1100 mm

Cabin length 1400 mm

Travel height..... 2150¹⁾-13000 mm

Hole through floor width.....1465-1590 mm

Hole through floor length..... 1630 mm

Top height (min) 2400 mm

Landingdoors:

Height of door opening.... 1800²⁾, 1900²⁾, 2000 mm

Width of door opening 900 mm

1) For opposite entry. 2300 mm when doors on same side.

2) Height of door opening for cabin door is always 2000 mm.

Specifications

Drive system: Patented screw/nut system

Rated speed: max 0.15 m/s

Cabin control: Automatic "one-touch"

Landing control: One-touch call

Technical compliance:

European Machinery Directive 2006/42/EC

Rated load: 400 kg / 5 persons

Number of stops: max 6

Pit: 75 mm (no pit is required when there is a ramp)

Environment: Indoors

Power supply: 3-phase 400V 50Hz/5.2A/16A slow

Emergency lowering: Battery- powered

Control voltage: 24 V

Motor: 3 kW

For more information, please, refer to our product catalogue or visit our website.

Due to the continuous product development at the company, the information may change without prior notice.



ARITCO (THAILAND) Co., Ltd.

130/3 Thientalay 24, Bangkhunthien-Chaytalay, Takham, Bangkhunthien, Bangkok 10150, Thailand

Tel: 02-408-0200, Fax: 02-683-8877,

Mobile: 088-333-5050, 088-333-9090

www.aritcothailand.com, facebook.com/Aritcothailand